

REVISIONS			
REV	DESCRIPTION	DATE	APPROVED
--	--	--	--

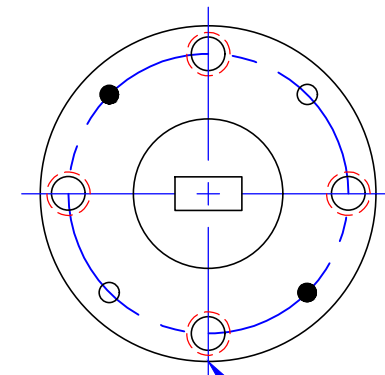
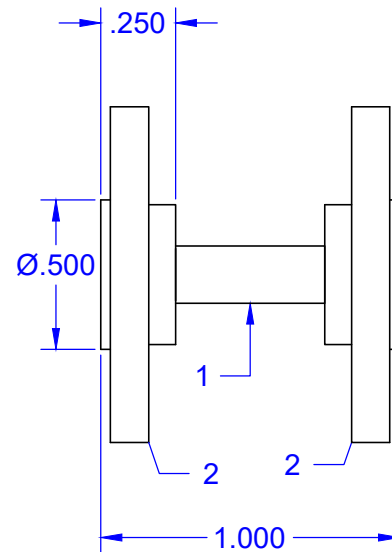
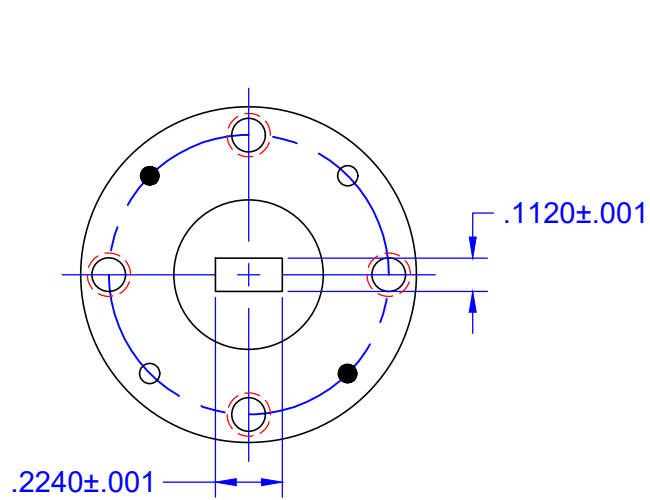

UG-383 FLANGE

2	STOCK	UG383 FLANGE		2	
1	STOCK	WR-22 WAVEGUIDE		1	
QTY	PART NUMBER	DESCRIPTION		ITEM	
UNLESS OTHERWISE SPECIFIED ALL SURFACES $\sqrt{32}$		 THIRD ANGLE PROJECTION		<b>Mi-Wave</b> Millimeter Products Inc.  <b>690B-1.00/383</b> <b>OUTLINE</b>	
DIMENSIONS ARE IN INCHES TOLERANCES ARE: DECIMALS: .1234 +/- .0005 .123 +/- .005 .12 +/- .01 ANGLES: +/- .5 DEGREES					
ALL THREADS TO BE 2A OR 2B		DRAFTING: K.S.	SIZE		DWG NO
REF DWG #: 12171		DATE: 8/20/2014	A		25874
		SHEET NO. 1	OF 1		